

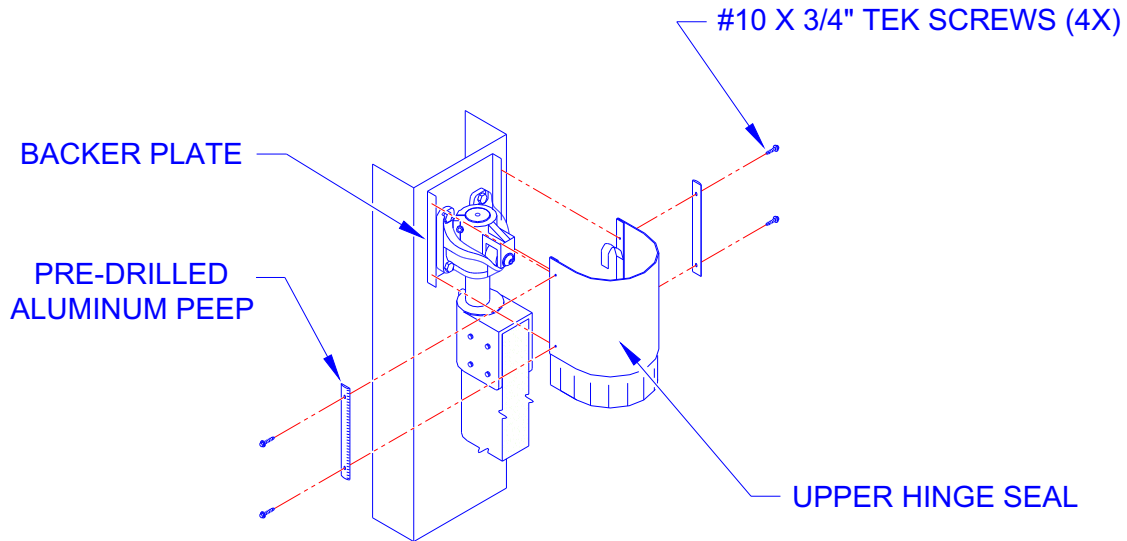

REINFORCED UPPER HINGE SEAL INSTALLATION INSTRUCTIONS

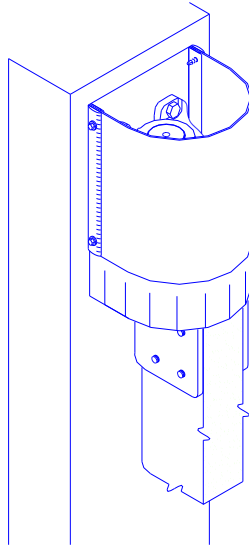

- A. PEEL PAPER FROM DOUBLE FACE TAPE ON HINGE SEAL.**
- B. ATTACH HINGE SEAL SKIRT SIDE DOWN TO BACKER PLATE, TOP OF HINGE SEAL SHOULD TOUCH JAMB HEADER.**
- C. PLACE PRE-DRILLED ALUMINUM PEEP OVER THE PORTION OF THE SEAL WHICH IS TAPED TO THE BACKER PLATE. ATTACH USING SUPPLIED #10 X 3/4" TEK SCREWS.**



UPPER HINGE SEAL ASSEMBLED