

180° Weld Plate Locations

DOOR HEIGHT	DIM "A"
78"	72 3/8"
80"	74 3/8"
84"	78 3/8"
90"	84 3/8"
96"	90 3/8"
102"	96 3/8"
108"	102 3/8"
114"	108 3/8"
120"	114 3/8"

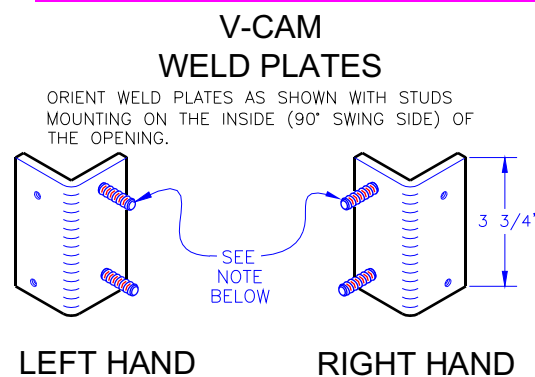

NOTE: 1/4-20 X 1" STUD LOCATED 3/8" FROM TOP AND 13/16" FROM EDGE.

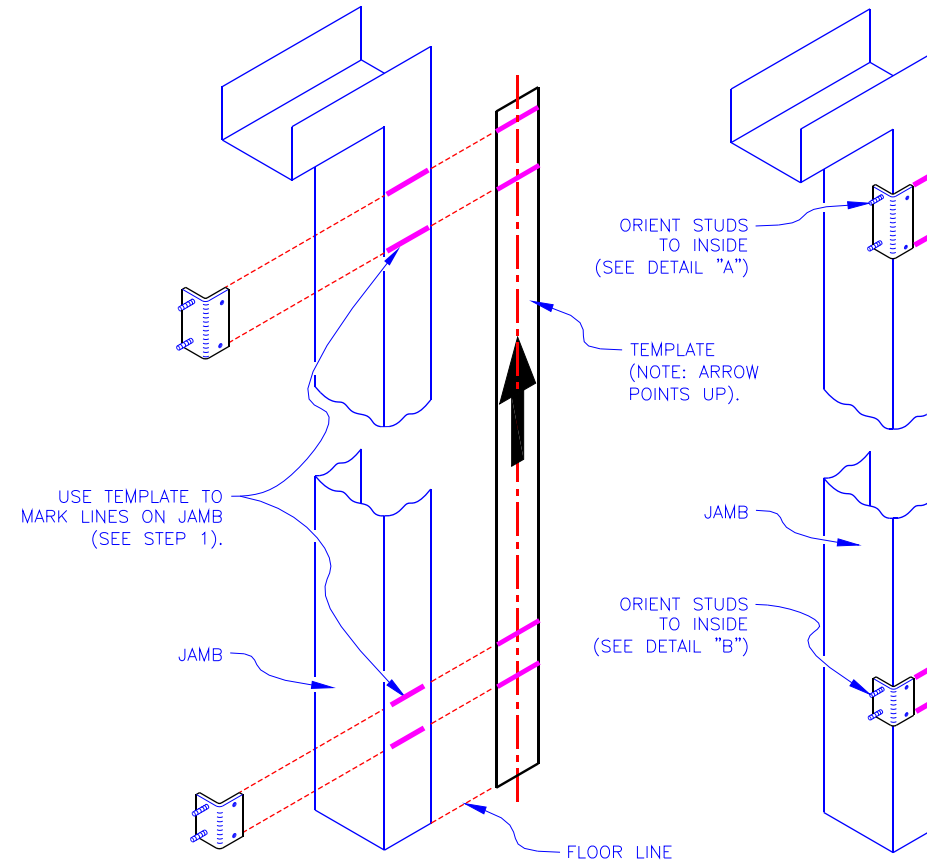
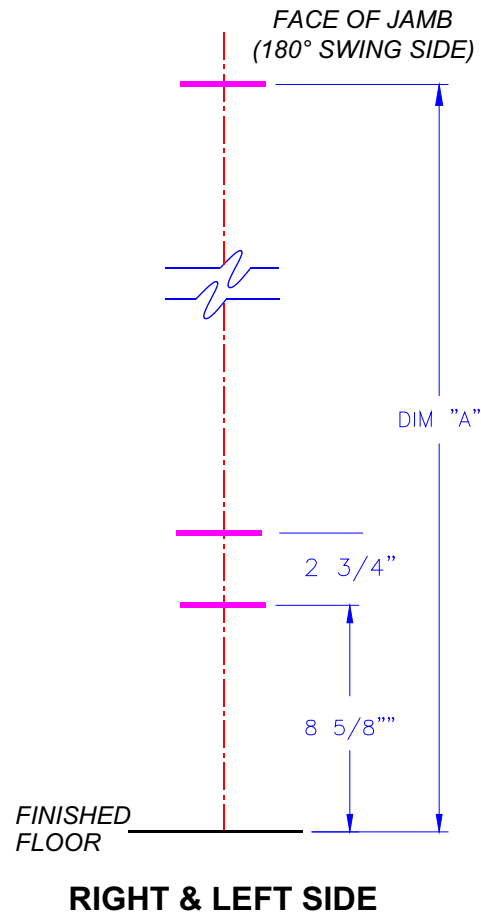
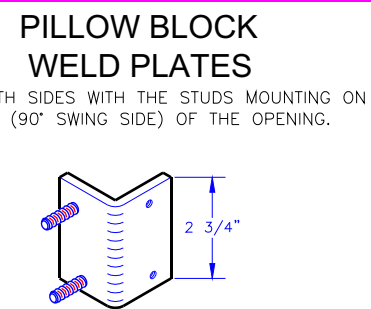

RIGHT HAND PILLOW BLOCK MOUNTS WITH THE PART NUMBER DOWN.

LEFT HAND PILLOW BLOCK MOUNTS WITH THE PART NUMBER UP.

Durulite® - 180° Weld Plate Instructions

STEP 1. TEMPLATE

FACE THE OPENING FROM THE 180° SWING SIDE. PLACE THE MOUNTING TEMPLATE ON THE FACE OF THE JAMB (THE 180° SIDE). WITH THE BOTTOM OF TEMPLATE RESTING ON THE FLOOR, MARK THE FOUR WELD PLATE MOUNTING LINES ON THE TEMPLATE, ONTO THE FACE OF THE JAMB. REMOVE TEMPLATE.

STEP 2. HARDWARE LOCATION

WELD PLATES HAVE BEEN SHIPPED ATTACHED TO THE MOUNTING HARDWARE AND SHOULD NOT BE REMOVED UNTIL HARDWARE HAS BEEN ORIENTED TO THE APPROPRIATE JAMB. ORIENT HARDWARE TO APPROPRIATE JAMB SIDES AS FOLLOWS: V-CAMS ARE MARKED "LH" FOR LEFT HAND AND "RH" FOR RIGHT HAND SIDE OF JAMBS. PILLOW BLOCKS ARE MARKED WITH A PART NUMBER. FOR WELD PLATE INSTALLATIONS ONLY, MOUNT THE RIGHT PILLOW BLOCK WITH THE PART NUMBER FACING DOWN. THE LEFT PILLOW BLOCK SHOULD BE MOUNTED WITH THE PART NUMBER FACING UP.

NOTE: ALL WELD PLATE STUDS SHOULD BE LOCATED ON THE INSIDE (90° SWING SIDE) OF THE JAMB AS SHOWN IN THE DRAWING AT LEFT.

STEP 3. MOUNTING WELD PLATES

AFTER LOCATING HARDWARE TO ITS APPROPRIATE JAMB, REMOVE WELD PLATES FROM MOUNTING HARDWARE. PLACE WELD PLATES BETWEEN SETS OF LINES MARKED ON JAMB FACE (SEE DRAWING AT LEFT). WELD THE WELD PLATES TO JAMB. DO NOT EXTEND BEADS ONTO FACE OF WELD PLATES.

COMPLETE DOOR INSTALLATION REFERRING TO "DURULITE 180° X 90° INSTALLATION INSTRUCTIONS" BEGINNING AT STEP 2.